

3 WAY 316 STAINLESS STEEL BALL VALVE DIRECT MOUNT #3L66RT-DM

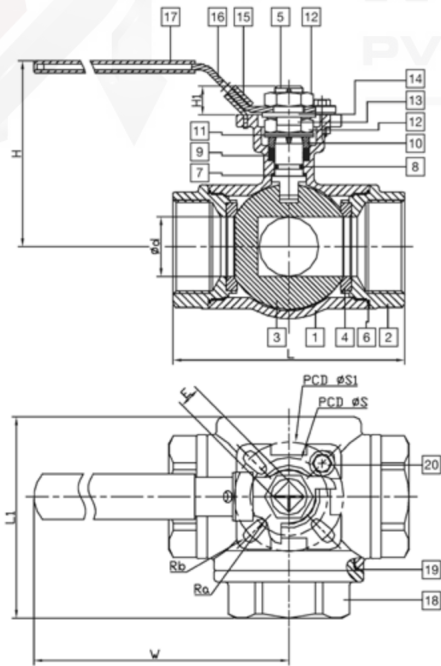

Item	Parts	Material
1	Body	ASTM A351-CF8M
2	Cap-A	ASTM A351-CF8M
3	Ball	ASTM A351-CF8M
4	Seat	PTFE
5	Stem	AISI 316
6	Seal-A	PTFE
7	Thrust Washer	PEEK + PTFE
8	O-Ring	VITON
9	Packing	PTFE
10	Gland	AISI 304
11	Belleville Washer	AISI 304
12	Stem Nut	AISI 304
13	Locking Washer	AISI 304
14	Handle Washer	ANSI 304
15	Locking Device	AISI 304
16	Handle	AISI 304
17	Handle Sleeve	PVC
18	Cap-B	ASTM A351-CF8M
19	Seal-B	PTFE
20	Stop Pin	AISI 304

SIZE	d	L	L1	H	W	S	S1	H1	E	Ra	Rb	Torque
1/4"	0.46	2.99	2.30	2.87	4.84	1.42	1.65	0.35	0.35	0.12	0.12	89
3/8"	0.49	2.99	2.30	2.87	4.84	1.42	1.65	0.35	0.35	0.12	0.12	89
1/2"	0.49	2.99	2.30	2.87	4.84	1.42	1.65	0.35	0.35	0.12	0.12	89
3/4"	0.63	3.39	2.83	2.99	4.84	1.42	1.65	0.35	0.35	0.12	0.12	133
1"	0.79	3.90	3.21	3.43	6.02	1.65	1.97	0.43	0.43	0.12	0.14	195
1-1/4"	0.98	4.61	3.72	3.66	6.02	1.65	1.97	0.43	0.43	0.12	0.14	266
1-1/2"	1.26	4.88	4.09	4.33	7.20	1.97	2.76	0.55	0.55	0.14	0.18	416
2"	1.50	5.83	4.92	4.69	7.20	1.97	2.76	0.55	0.55	0.14	0.18	514

*Actual torque values may vary. Please consult the factory.

**All torque values are in in-lb. Weight values are in lb.

