

2 PIECE HIGH PRESSURE 316 STAINLESS STEEL BALL VALVE #3266HP-3266HPW

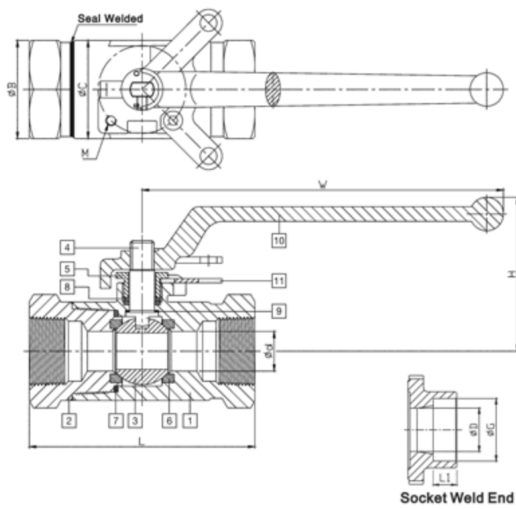

COLE
INDUSTRIAL
PVF | SANITARY | STRUCTURAL
—STREAMLINED—



Item	Description	Material
1	Body	ASTM A351-CF8M
2	Cap	ASTM A351-CF8M
3	Ball	ASTM A351-CF8M
4	Stem	ASTM A276-316
5	Gland Nut	AISI 304
6	Seat	PEEK
7	Seal	GRAPHITE
8	Packing	GRAPHITE
9	Thrust Washer	CTFE
10	Handle	AISI 304
11	Locking Pad	AISI 304

SIZE	L	L1	D	G	H	W	d	B	C	ISO 5211	M	Torque	WT
1/4" F	3.00	0.39	0.31	0.55	2.23	5.59	0.25	1.26	1.54	F03	M5*P0.8	85	1.50
1/2" F	4.00	0.39	0.59	0.87	2.23	5.59	0.50	1.26	1.54	F03	M5*P0.8	85	1.70
3/4" F	4.25	0.51	0.79	1.08	3.00	6.81	0.75	1.85	1.85	F04	M5*P0.8	248	3.00
1" S	4.25	0.51	0.94	1.36	3.00	6.81	0.75	1.85	1.85	F04	M5*P0.8	248	2.80
1-1/2" F	5.28	0.51	1.50	1.93	4.61	9.74	1.50	3.03	3.39	F07	M8*P1.25	470	10.80
2" S	6.22	0.63	1.97	2.41	4.61	9.74	1.50	3.23	3.39	F07	M8*P1.25	470	11.80

*Actual torque values may vary. Please consult the factory.

**All torque values are in in-lb. Weight values are in lb.

